

The Jamming Game in an OFDM Setting

Francesco Renna
Department of Information
Engineering
University of Padua
frarena@dei.unipd.it

Nicola Laurenti
Department of Information
Engineering
University of Padua
nil@dei.unipd.it

Yih-Chun Hu
Coordinated Science
Laboratory
University of Illinois
yihchun@illinois.edu

ABSTRACT

Orthogonal frequency division multiplexing (OFDM) has been chosen as the physical layer solution for a large variety of emerging and future wireless networks, due to its robustness in coping with frequency selective channels and efficient transceiver implementation. Its adoption in the transmission architecture should therefore be properly taken into account when designing or analyzing security solutions at the physical layer. We consider a jamming game with OFDM transmission, that is a zero-sum game between transmitter/receiver and jammer where the payoff function is the mutual information between the transmitted and received symbols, and we assume complete knowledge of the channel states and uncorrelated jamming. By establishing similarity with a MIMO Gaussian channel we evaluate the payoff function at the Nash equilibrium and derive the optimal signaling strategies to be implemented by the transmitter and the jammer.

Categories and Subject Descriptors

C.2.0 [Computer-communication networks]: General—Security and protection; C.2.1 [Computer-communication networks]: Network architecture and design—Wireless communication

General Terms

Security

Keywords

OFDM, jamming, mutual information game

1. INTRODUCTION

Jamming has traditionally represented a serious attack to the availability of transmission over wireless links. Since the last century, a lot of attention has been devoted to devising effective strategies against it, especially in the field of military communications.

However, a game-theoretic formulation of the jamming problem has only been proposed in the '80s [3, 4]. Such formulations describe it as a zero-sum game played by two adversaries: the transmitter/receiver pair on one side, and the jammer on the other. The payoff function, which the transmitter seeks to maximize, and the jammer to minimize, is the mutual information between the transmitted and received signals, while constraints on the possible strategies are set by power and energy limitations. Starting from the first results on the Gaussian channel, extensions to different scenarios have followed, such as multiple-input multiple-output (MIMO) channels [5, 12, 11], the wideband channel limit [14], and fading channels [12, 1, 2]. In most cases the jamming game has a saddle point solution, that is a pair of strategies (one for the transmitter/receiver, the other for the jammer) that are each one optimal for the corresponding player, given that the opponent follows his optimal strategy. Thus they represent a Nash equilibrium, although convergence to it is not guaranteed.

When expressing the jamming game in information theoretic terms, it is not customary to consider a particular modulation format. On the other hand, orthogonal frequency division multiplexing (OFDM) has been chosen in recent years as the physical layer technique for a large variety of emerging and future wireless networks, due to its robustness in coping with frequency selective channels and efficient transceiver implementation. Therefore we feel that its adoption in the transmission architecture should be properly taken into account when designing or analyzing security solutions at the physical layer. Little has been done in the literature with respect to the jamming problem within an OFDM framework: for example [6, 7] consider the robustness of the multicarrier scheme to certain types of jammers (single tone, narrowband Gaussian, etc.). To our knowledge, the only attempt so far to apply an information theoretic jamming game to the OFDM channel is given in [16] where, however, the system is modeled as the parallel of M channels, each independently jammed. We prefer to relax this assumption and allow arbitrarily correlated inputs for both the transmitter and the jammer, and look for saddle point solution in this model.

The paper is organized as follows. In Section 2 we introduce a general system model, comprising different OFDM varieties, and the jamming model. In Section 3 we formulate the jamming game as a minimax problem under trace constraints. Then, in Section 4, we obtain an elegant solution

Permission to make digital or hard copies of all or part of this work for personal or classroom use is granted without fee provided that copies are not made or distributed for profit or commercial advantage and that copies bear this notice and the full citation on the first page. To copy otherwise, or republish, to post on servers or to redistribute to lists, requires prior specific permission and/or a fee. GameComm 2011, Paris, France. Copyright © 2011 ICST. ISBN 978-1-936968-08-4

by relaxing some constraint, then in Section 5 investigate in what cases the constraint relaxation has no effect on the optimal solution, so that the one derived in Section 4 can still be used. In Section 6 we present results in the more general case, and eventually draw conclusions.

As regards the notation, we will use boldface lowercase letters for vectors (rows or columns), and boldface uppercase for matrices. The complex conjugate (Hermitian) of a matrix \mathbf{A} will be indicated as \mathbf{A}^* , while the (positive semidefinite) square root of a positive semidefinite matrix is denoted by $\sqrt{\mathbf{A}}$. We indicate the partial ordering within positive semidefinite matrices as \succ , that is we write $\mathbf{A} \succ \mathbf{B}$ to state that $\mathbf{A} - \mathbf{B}$ is a positive semidefinite matrix.

2. SYSTEM MODEL

The model we use comprises both the discrete multitone (DMT) systems with cyclic prefix (CP) and zero pad suffix (ZS) [13] as well as the filtered multitone (FMT) systems, both critically sampled (CS) and non-critically sampled (NS) [8], and is illustrated in Figure 1. Let M be the number of used subcarriers, T the OFDM symbol period and F the subcarrier spacing, so that each subcarrier frequency is $f_i = m_i F$, $i = 1, \dots, M$ with m_i a suitable integer. Then, the (baseband equivalent of the) transmitted signal for a packet of K symbols can be written as the combination of the transmit waveforms

$$x(t) = \sum_{k=1}^K \sum_{i=1}^M u_i(kT) \gamma_i(t - kT) \quad (1)$$

with $u_i(kT)$ being the data in the i th subchannel and k th symbol, while $\gamma_i(t) = \gamma_0(t) e^{j2\pi f_i t}$ is the frequency shifted version of a common waveform $\gamma_0(t)$. Similarly, the demodulator produces the symbols $y_i(kT)$ by taking the inner product between the received signal and the receiver waveforms

$$y_i(kT) = \int \varphi_i^*(t - kT) y(t) dt \quad , \quad \begin{array}{l} i = 1, \dots, M \\ k = 1, \dots, K \end{array} \quad (2)$$

where $\varphi_i(t) = \varphi_0(t) e^{j2\pi f_i t}$. Note that the peculiar structure of the transmit and receive waveforms allows to efficiently implement both the modulator and demodulator via fast Fourier transform (FFT).

The channel is assumed to be linear and time-invariant and hence act as a filter $g_T(\cdot)$ on the transmitted signal, so that its output is

$$x'(t) = x * g_T(t) = \sum_{k=1}^K \sum_{i=1}^M u_i(kT) \gamma'_i(t - kT) \quad (3)$$

with $\gamma'_i = \gamma_i * g_T$.

Within this general frame, different OFDM types are identified by the relation between carrier spacing F and symbol period T , and by the expression of the basic waveforms $\gamma_0(t)$ and $\varphi_0(t)$, as given in Table 1. Note the difference between φ_0 and γ_0 in the DMT, which accomodates for the channel delay spread, and avoids interchannel interference with linear time-invariant channels shorter than $T_g = T - 1/F$.

Along with legitimate transmission the receiver is also subject to jamming, that is an unwanted signal $s(t)$ transmit-

ed by an adversary, which, through another linear time-invariant channel $g_J(\cdot)$, reaches the receiver as $s'(t) = s * g_J(t)$. Hence, by also including the noise $w(t)$, modeled as circularly symmetric complex Gaussian with power spectral density (PSD) $2N_0$ we get

$$y(t) = x'(t) + s'(t) + w(t) \quad (4)$$

By gathering all data symbols of a packet into a single column vector $\mathbf{u} = [u_1(T), \dots, u_M(KT)]^T$, and all transmit waveforms into a row $\boldsymbol{\gamma}(t) = [\gamma_1(t - T), \dots, \gamma_M(t - KT)]$ we can rewrite (1) as

$$x(t) = \boldsymbol{\gamma}(t) \mathbf{u} \quad (5)$$

Hence, we express the instantaneous transmitted power as

$$|x(t)|^2 = \boldsymbol{\gamma}(t) \mathbf{u} \mathbf{u}^* \boldsymbol{\gamma}^*(t) = \text{tr} [\mathbf{u} \mathbf{u}^* \boldsymbol{\gamma}^*(t) \boldsymbol{\gamma}(t)] \quad (6)$$

and the mean energy per packet as

$$E_x = \mathbb{E} \left\{ \int |x(t)|^2 dt \right\} = \mathbb{E} \left\{ \int \text{tr} [\mathbf{u} \mathbf{u}^* \boldsymbol{\gamma}^*(t) \boldsymbol{\gamma}(t)] dt \right\} \quad (7)$$

$$= \text{tr} \left[\mathbb{E} \{ \mathbf{u} \mathbf{u}^* \} \int \boldsymbol{\gamma}^*(t) \boldsymbol{\gamma}(t) dt \right] = \text{tr} (\mathbf{K}_u \mathbf{E}_\gamma) \quad (8)$$

where \mathbf{K}_u is the correlation matrix of \mathbf{u} and \mathbf{E}_γ is the matrix of cross energies between waveforms in $\boldsymbol{\gamma}(t)$. Similarly, the output of the legitimate channel can be written as $x'(t) = \boldsymbol{\gamma}'(t) \mathbf{u}$ with $\boldsymbol{\gamma}'(t) = \int \boldsymbol{\gamma}(u) g_T(t - u) du$.

If we write the receiver output as a column vector $\mathbf{y} = [y_1(T), \dots, y_M(KT)]^T$ and the waveforms as a row vector $\boldsymbol{\varphi}(t) = [\varphi_1(t - T), \dots, \varphi_M(t - KT)]$, from the decomposition of the received signal in (4), we have

$$\mathbf{y} = \int \boldsymbol{\varphi}^*(t) y(t) dt = \mathbf{x} + \mathbf{s} + \mathbf{w}$$

with

$$\mathbf{x} = \int \boldsymbol{\varphi}^*(t) x'(t) dt = \int \boldsymbol{\varphi}^*(t) \boldsymbol{\gamma}'(t) \mathbf{u} dt = \mathbf{E}_{\boldsymbol{\varphi}' \boldsymbol{\gamma}'} \mathbf{u} \quad (9)$$

$$\mathbf{w} = \int \boldsymbol{\varphi}^*(t) w(t) dt \quad , \quad \mathbf{w} \sim \mathcal{N}(\mathbf{0}, \mathbf{K}_w) \quad , \quad \mathbf{K}_w = 2N_0 \mathbf{E}_\varphi \quad (10)$$

$$\mathbf{s} = \int \boldsymbol{\varphi}^*(t) s'(t) dt = \int \boldsymbol{\varphi}'^*(t) s(t) dt \quad (11)$$

In (11) we have introduced $\boldsymbol{\varphi}'(t) = \int \boldsymbol{\varphi}(u) g_J^*(u - t) du$, so it is easy to see that only the components of $s(t)$ lying in the span of the waveforms $\varphi'_i(t - kT)$ give a nonzero contribution to the receiver output, and can influence the receiver performance. Without loss of generality, we can therefore assume $s(t) = \boldsymbol{\varphi}'(t) \mathbf{v}$, with \mathbf{v} a column vector chosen by the jammer. Analogously to (8) and (9), we can then write

$$E_s = \text{tr} (\mathbf{K}_v \mathbf{E}_{\boldsymbol{\varphi}'}) \quad , \quad \mathbf{s} = \mathbf{E}_{\boldsymbol{\varphi}'} \mathbf{v}$$

The so reduced vector-based model is illustrated in Figure 2.

Observe that the above model, introduced with a continuous-time notation can be converted to discrete-time by properly sampling the waveforms and replacing integrals with summations.

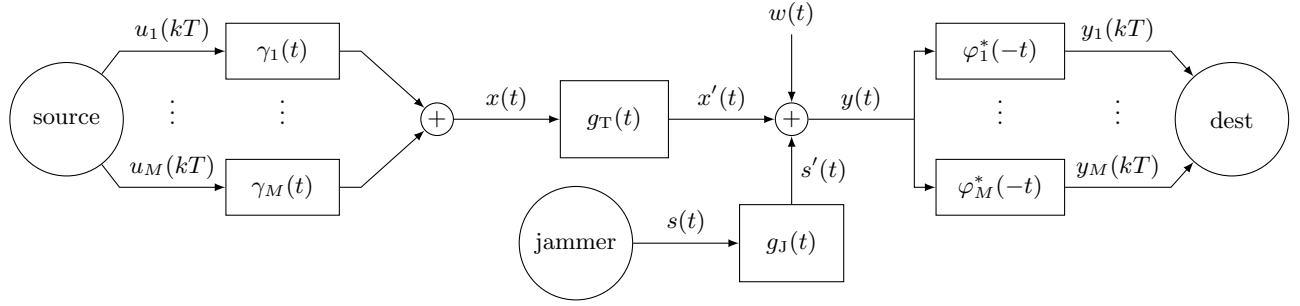

Figure 1: Block diagram of an OFDM system with time-invariant channels and an uncorrelated jammer.

Table 1: Parameters and filters for common OFDM systems in the general model. The notation $\mathbb{U}_a^b(t)$ represents the unit amplitude rectangular signal extending from a to b , while $\text{rcos}(\rho, x)$ represents the raised cosine with roll-off ρ .

system	efficiency	transmit and receive filters	bandwidth	packet duration
DMT/CP	$FT = 1 + \rho$	$\gamma_0(t) = \sqrt{F}\mathbb{U}_{-\rho/F}^{1/F}(t)$, $\varphi_0(t) = \sqrt{F}\mathbb{U}_0^{1/F}(t)$	$B_x > MF$	$T_p = KT$
DMT/ZS	$FT = 1 + \rho$	$\gamma_0(t) = \sqrt{F}\mathbb{U}_0^{1/F}(t)$, $\varphi_0(t) = \sqrt{F}\mathbb{U}_0^T(t)$	$B_x > MF$	$T_p = KT$
FMT/CS	$FT = 1$	$\Gamma_0(f) = \Phi_0(f) = \sqrt{T(1 + \rho)\text{rcos}(\rho, T(1 + \rho)f)}$	$B_x = MF$	$T_p > KT$
FMT/NS	$FT = 1 + \rho$	$\Gamma_0(f) = \Phi_0(f) = \sqrt{T}\text{rcos}(\rho, Tf)$	$B_x = MF$	$T_p > KT$

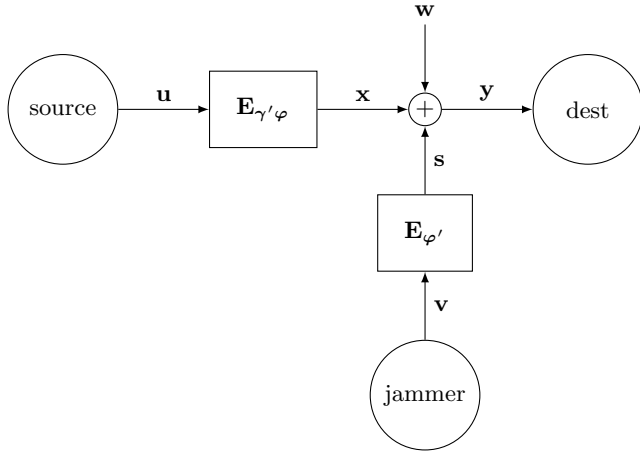

Figure 2: Equivalent block diagram of the system in Figure 1, corresponding to (9) and (2). Here the blocks represents matrix multiplications.

3. PROBLEM STATEMENT

We consider a zero-sum game between the transmitter/receiver pair on one side, and the jammer on the other, where the payoff function is the mutual information $I(\mathbf{u}; \mathbf{y})$ between the input to the OFDM transmitter and the output of the OFDM receiver. All the players in the game have complete knowledge about both channels and the strategy adopted by the adversary. However, neither the legitimate transmitter nor the jammer can observe the signal transmitted by the other. Given that the channel is linear and Gaussian, and

the energy constraints, the optimal strategies for both the transmitter and jammer are Gaussian [3, 11]. Moreover we look for the existence of a common maximin and minimax solution, so that

$$\max_{\mathbf{u}} \min_{\mathbf{v}} I(\mathbf{u}; \mathbf{y}) = \min_{\mathbf{v}} \max_{\mathbf{u}} I(\mathbf{u}; \mathbf{y}) \quad (12)$$

represents a saddle point in the payoff function. When assuming independent Gaussian \mathbf{u}, \mathbf{v} the mutual information between \mathbf{u} and \mathbf{y} is given by

$$I(\mathbf{u}; \mathbf{y}) = \log_2 \frac{|\mathbf{K}_x + \mathbf{K}_w + \mathbf{K}_s|}{|\mathbf{K}_w + \mathbf{K}_s|} \quad (13)$$

where

$$\mathbf{K}_x = \mathbf{E}_{\gamma' \varphi} \mathbf{K}_u \mathbf{E}_{\gamma' \varphi}^* \quad , \quad \mathbf{K}_s = \mathbf{E}_{\varphi'} \mathbf{K}_v \mathbf{E}_{\varphi'} \quad (14)$$

as $\mathbf{E}_{\varphi'}$ is Hermitian.

The average energy per packet for the transmitter and the jammer are constrained by E_T and E_J , respectively. For later use, we also define the transmission signal to noise ratio (SNR) and jammer to noise ratio (JNR) as the transmitted signal energy constraints normalized over the noise energy, $\rho_T = E_T/(2N_0MK)$ and $\rho_J = E_J/(2N_0MK)$, respectively.

Formally, we can then write the minimax problem as

$$\min_{\mathbf{K}_v} \max_{\mathbf{K}_u} \{ \log_2 |\mathbf{I} + \mathbf{K}_x (\mathbf{K}_w + \mathbf{K}_s)^{-1}| \} \quad (15)$$

subject to:

$$\mathbf{K}_u \succ \mathbf{0} \quad , \quad \text{tr}(\mathbf{K}_u \mathbf{E}_{\gamma'}) \leq E_T \quad (16)$$

$$\mathbf{K}_v \succ \mathbf{0} \quad , \quad \text{tr}(\mathbf{K}_v \mathbf{E}_{\varphi'}) \leq E_J \quad (17)$$

The payoff function (15) is convex with respect to \mathbf{K}_v and concave with respect to \mathbf{K}_u , hence within the convex set determined by the constraints (16) and (17) it admits a saddle point solution.

By assuming that $\mathbf{E}_{\gamma'/\varphi}$ and $\mathbf{E}_{\varphi'}$ are nonsingular and defining the Hermitian matrices

$$\mathbf{P} = \sqrt{\mathbf{E}_{\gamma'/\varphi}^{-1} \mathbf{E}_{\gamma} \mathbf{E}_{\gamma'/\varphi}^{-*}} \quad , \quad \mathbf{Q} = \sqrt{\mathbf{E}_{\varphi'}^{-1}} \quad (18)$$

we can express the traces in the energy constraints (16)–(17) as

$$\text{tr}(\mathbf{K}_u \mathbf{E}_{\gamma}) = \text{tr}(\mathbf{P} \mathbf{K}_x \mathbf{P}) \quad , \quad \text{tr}(\mathbf{K}_v \mathbf{E}_{\varphi'}) = \text{tr}(\mathbf{Q} \mathbf{K}_s \mathbf{Q}). \quad (19)$$

Then, with the substitutions

$$\mathbf{H} = \mathbf{Q} \mathbf{P}^{-1} \quad , \quad \tilde{\mathbf{K}}_x = \mathbf{P} \mathbf{K}_x \mathbf{P} \quad (20)$$

$$\tilde{\mathbf{K}}_s = \mathbf{Q} \mathbf{K}_s \mathbf{Q} \quad , \quad \tilde{\mathbf{K}}_w = \mathbf{Q} \mathbf{K}_w \mathbf{Q} = 2N_0 \mathbf{Q} \mathbf{E}_{\varphi} \mathbf{Q} \quad , \quad (21)$$

the minimax problem can be written as

$$\min_{\tilde{\mathbf{K}}_s} \max_{\tilde{\mathbf{K}}_x} \left\{ \log_2 |\mathbf{I} + \mathbf{H} \tilde{\mathbf{K}}_x \mathbf{H}^* (\tilde{\mathbf{K}}_w + \tilde{\mathbf{K}}_s)^{-1}| \right\} \quad (22)$$

subject to:

$$\tilde{\mathbf{K}}_x \succ \mathbf{0} \quad , \quad \text{tr}(\tilde{\mathbf{K}}_x) \leq E_T \quad (23)$$

$$\tilde{\mathbf{K}}_s \succ \mathbf{0} \quad , \quad \text{tr}(\tilde{\mathbf{K}}_s) \leq E_J \quad (24)$$

which is the form of a jamming game for the MIMO transmission channel \mathbf{H} , with ideal jamming channel and noise covariance matrix $\tilde{\mathbf{K}}_w$.

4. SADDLE-POINT SOLUTION IN THE HIGH JNR REGIME

Allow us, for the time being, to introduce one more rewriting of the minimax problem, by letting $\mathbf{z} = \mathbf{s} + \mathbf{w}$. Then, with $\mathbf{K}_z = \mathbf{K}_s + \mathbf{K}_w$ and $\tilde{\mathbf{K}}_z = \mathbf{Q} \mathbf{K}_z \mathbf{Q}$ the problem (22)–(24) becomes

$$\min_{\tilde{\mathbf{K}}_z} \max_{\tilde{\mathbf{K}}_x} f(\tilde{\mathbf{K}}_x, \tilde{\mathbf{K}}_z) \quad (25)$$

with

$$f(\tilde{\mathbf{K}}_x, \tilde{\mathbf{K}}_z) = \log_2 |\mathbf{I} + \tilde{\mathbf{K}}_z^{-1/2} \mathbf{H} \tilde{\mathbf{K}}_x \mathbf{H}^* \tilde{\mathbf{K}}_z^{-1/2}|, \quad (26)$$

subject to:

$$\tilde{\mathbf{K}}_x \succ \mathbf{0} \quad , \quad \text{tr}(\tilde{\mathbf{K}}_x) \leq E_T \quad (27)$$

$$\tilde{\mathbf{K}}_z \succ \tilde{\mathbf{K}}_w \quad , \quad \text{tr}(\tilde{\mathbf{K}}_z) \leq E_J + \text{tr}(\tilde{\mathbf{K}}_w) \quad (28)$$

Now, if we relax the first constraint in (28) to $\tilde{\mathbf{K}}_z \succ \mathbf{0}$, we obtain a modified problem where the feasibility region is expanded. The saddle-point solution for such a problem was given in [11], [10, Theorem 8] as

$$f(\tilde{\mathbf{K}}_x^*, \tilde{\mathbf{K}}_z^*) = \log_2 |\mathbf{I} + \Lambda \mathbf{H} \mathbf{H}^*|, \quad (29)$$

where we have denoted with Λ the equivalent signal to jammer plus noise ratio (SJNR),

$$\Lambda = \frac{E_T}{E_J + \text{tr}(\tilde{\mathbf{K}}_w)}. \quad (30)$$

Moreover, on writing the singular values decomposition (SVD) of the channel \mathbf{H} as $\mathbf{H} = \mathbf{U}_H \Sigma_H^{1/2} \mathbf{V}_H^*$, the optimal covariance matrices for the transmitter and the attacker are given by

$$\tilde{\mathbf{K}}_x^* = \mathbf{V}_H \Sigma_x \mathbf{V}_H^* \quad , \quad \tilde{\mathbf{K}}_z^* = \mathbf{U}_H \Sigma_z \mathbf{U}_H^* \quad , \quad (31)$$

meaning that the transmitter should beamform the information carrying signal along the directions corresponding to the right singular vectors of the channel, whereas the attacker should distribute the jamming power along the left singular vectors of the channel. With such covariance matrices, it is easy to notice that the whole system becomes equivalent to the parallel of Gaussian channels with SNRs determined by the values in the diagonal matrices Σ_H , Σ_x and Σ_z .

Observe that since we have relaxed the constraint for $\tilde{\mathbf{K}}_z$, the optimal solution (29) to the relaxed problem will in general yield a value of the payoff function that is lower than or equal to the solution to the original problem. However, if the saddle point (31) also satisfies the constraint (28), then it coincides with the solution for the original problem. It is clear that if E_J is very high, the feasible region for the original problem will be large and the two solutions will be more likely to coincide. Therefore, we call the solution of the relaxed problem the “high JNR” solution. In Section 5 we will characterize the thresholds on the JNR for which the solution is feasible.

4.1 AWGN channel case

We start by considering the simple case in which both channels from the transmitter and the adversary towards the receiver are additive white Gaussian noise (AWGN) channels.

Under this assumption, it is possible to show that the energy matrices for the NS system are all equal to the identity matrix, $\mathbf{E}_{\gamma} = \mathbf{E}_{\varphi} = \mathbf{E}_{\varphi'} = \mathbf{E}_{\gamma'/\varphi} = \mathbf{I}$, and consequently $\mathbf{H} = \mathbf{I}$ and $\tilde{\mathbf{K}}_w = 2N_0 \mathbf{I}$. Hence, the payoff at the saddle point for the NS system over AWGN channels is

$$f(\tilde{\mathbf{K}}_x^*, \tilde{\mathbf{K}}_z^*) = MK \log_2(1 + \Lambda), \quad (32)$$

with SJNR given by

$$\Lambda = \frac{E_T}{E_J + 2N_0 MK}, \quad (33)$$

that is the ratio between the available energy at the transmitter and the sum of the available energy of the jammer plus the energy of the receiver thermal noise. The saddle point solution is exactly the capacity of MK parallel Gaussian channels with SNR, equal to Λ and the Nash equilibrium is reached by independent, uniform power allocation for both the transmitter and the attacker

$$\mathbf{K}_x^* = \tilde{\mathbf{K}}_x^* = \frac{E_T}{MK} \mathbf{I} \quad , \quad \mathbf{K}_z^* = \tilde{\mathbf{K}}_z^* = \left(\frac{E_J}{MK} + 2N_0 \right) \mathbf{I}. \quad (34)$$

When CS transmission is adopted, instead, even if the channels are AWGN, intersymbol interference (ISI) does arise, as the CS transmission/reception filters do not comply with the Nyquist criterion. Although this system can not be modeled as parallel Gaussian channels, we can show that the CS architecture yields the same saddle point reached by the NS modulation. In fact, the energy matrices of the transmitter and receiver filters are not diagonal but they are given by $\mathbf{E}_{\gamma} = \mathbf{E}_{\varphi} = \mathbf{E}_{\varphi'} = \mathbf{E}_{\gamma'/\varphi} = \mathbf{A}$, where the positive semidefinite matrix \mathbf{A} can be compactly written in terms of the Kronecker product as

$$\mathbf{A} = \mathbf{A}_K \otimes \mathbf{I}_M, \quad (35)$$

with the general entry for \mathbf{A}_K being

$$A_{k,n} = \text{ircos} \left(\rho, \frac{k-n}{1+\rho} \right), \quad k, n = 1, \dots, K \quad (36)$$

and

$$\text{ircos}(\rho, x) = \text{sinc}(x) \frac{\pi}{4} [\text{sinc}(\rho x + 1/2) + \text{sinc}(\rho x - 1/2)]$$

being the inverse Fourier transform of the raised cosine pulse with roll-off factor ρ . Then, the equivalent MIMO channel matrix \mathbf{H} is still equal to the identity matrix, as

$$\mathbf{H} = \mathbf{Q}\mathbf{P}^{-1} = \sqrt{\mathbf{A}^{-1}} \left(\sqrt{\mathbf{A}^{-1}\mathbf{A}\mathbf{A}^{-1}} \right)^{-1} = \mathbf{I}, \quad (37)$$

and also the noise covariance

$$\tilde{\mathbf{K}}_{\mathbf{w}} = 2N_0 \sqrt{\mathbf{A}^{-1}} \mathbf{A} \sqrt{\mathbf{A}^{-1}} = 2N_0 \mathbf{I}. \quad (38)$$

Therefore, the CS system provides the same payoff value in (32) at the equilibrium, but the optimal covariance matrices for the transmitter and the jammer are now

$$\mathbf{K}_{\mathbf{x}}^* = \frac{E_T}{MK} \mathbf{A}, \quad \mathbf{K}_{\mathbf{z}}^* = \left(\frac{E_J}{MK} + 2N_0 \right) \mathbf{A}. \quad (39)$$

Under the assumption that the channels are not frequency selective, it is possible to also perform the analysis of the DMT systems. In particular, it is possible to compactly express the energy matrices also for the non-orthogonal families of waveforms of both the architectures; that is, the transmitter waveforms for CP, and the receiver waveforms for ZS. In the ZS case, we have

$$\mathbf{E}_{\varphi} = \mathbf{B} = \mathbf{I}_K \otimes \mathbf{B}_M, \quad (40)$$

in which the general entry of the matrix \mathbf{B}_M is given by

$$B_{i\ell} = \begin{cases} j \frac{1 - e^{j2\pi(m_\ell - m_i)\rho}}{2\pi(m_\ell - m_i)} & , \quad i \neq \ell \\ 1 + \rho & , \quad i = \ell \end{cases}. \quad (41)$$

On the other hand, in the CP case, we have

$$\mathbf{E}_{\gamma} = \mathbf{D}\mathbf{B}\mathbf{D}^* \quad , \quad \mathbf{D} = \mathbf{I}_K \otimes \text{diag}(e^{j2\pi m_i \rho})_{i=1, \dots, M}, \quad (42)$$

Hence, for cyclic-prefix transmission it holds $\mathbf{P} = \sqrt{\mathbf{D}\mathbf{B}\mathbf{D}^*}$ and $\mathbf{Q} = \mathbf{I}$, whereas, when the zero-padding suffix is implemented, we have $\mathbf{P} = \mathbf{I}$ and $\mathbf{Q} = \sqrt{\mathbf{B}^{-1}}$. In both cases $\tilde{\mathbf{K}}_{\mathbf{w}} = 2N_0 \mathbf{I}$ and the eigenvalues of $\mathbf{H}\mathbf{H}^*$ are equal to the eigenvalues of \mathbf{B}^{-1} . Then, the saddle point solution for both DMT architectures is given by

$$f(\tilde{\mathbf{K}}_{\mathbf{x}}^*, \tilde{\mathbf{K}}_{\mathbf{z}}^*) = \log_2 |\mathbf{I} + \Lambda \mathbf{B}^{-1}| \quad (43)$$

$$= K \sum_{i=1}^M \log_2 \left(1 + \frac{1}{\lambda_i(\mathbf{B}_M)} \Lambda \right) \quad (44)$$

where $\{\lambda_i(\mathbf{B}_M)\}$ are the eigenvalues of \mathbf{B}_M .

In Table 2 we summarize the cross-energy matrices of interest in the AWGN case.

A simplification of the result (44) can be obtained by considering a discrete-time model of DMT, where the sampling frequency is $F_s = MF$ and $m_i = m_0 + iF$, $i = 1, \dots, M$. Then, the expression of $B_{i\ell}$ changes from (41) to

$$B_{i\ell} = \begin{cases} \frac{1 - e^{j2\pi(m_\ell - m_i)\rho}}{1 - e^{j2\pi(m_\ell - m_i)/M}} & , \quad i \neq \ell \\ 1 + \rho & , \quad i = \ell \end{cases}. \quad (45)$$

system	\mathbf{E}_{γ}	\mathbf{E}_{φ}	$\mathbf{E}_{\gamma\varphi}$	\mathbf{P}	\mathbf{Q}
FMT/NS	\mathbf{I}	\mathbf{I}	\mathbf{I}	\mathbf{I}	\mathbf{I}
FMT/CS	\mathbf{A}	\mathbf{A}	\mathbf{A}	$\sqrt{\mathbf{A}^{-1}}$	$\sqrt{\mathbf{A}^{-1}}$
DMT/ZS	\mathbf{I}	\mathbf{B}	\mathbf{I}	\mathbf{I}	$\sqrt{\mathbf{B}^{-1}}$
DMT/CP	$\mathbf{D}\mathbf{B}\mathbf{D}^*$	\mathbf{I}	\mathbf{I}	$\sqrt{\mathbf{D}\mathbf{B}\mathbf{D}^*}$	\mathbf{I}

Table 2: Waveform cross-energy matrices for different OFDM systems when both the transmission and jamming channels are AWGN (in this case $\mathbf{E}_{\varphi'} = \mathbf{E}_{\varphi}$ and $\mathbf{E}_{\gamma'\varphi} = \mathbf{E}_{\gamma\varphi}$).

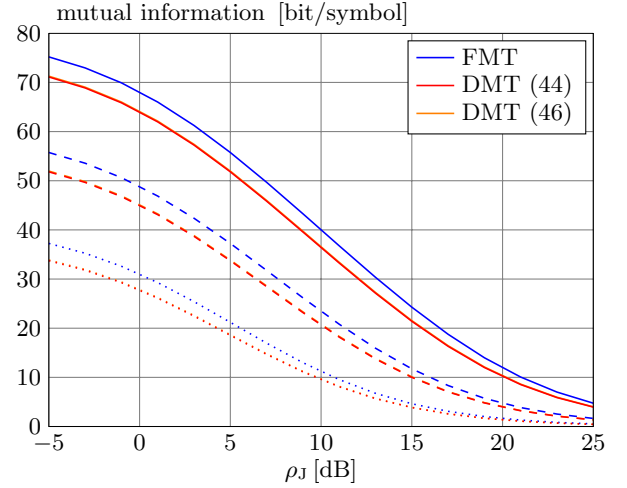

Figure 3: Mutual information vs. JNR at the Nash equilibrium, for OFDM transmissions over AWGN channels. Results are reported for 3 different SNR values, $\rho_T = 10$ dB (dotted lines), $\rho_T = 15$ dB (dashed lines) and $\rho_T = 20$ dB (solid lines). Curves obtained with the continuous time model (44) and with the discrete time approximation (46) overlap throughout the whole JNR range.

while (42) still holds. Then, it can be easily seen that \mathbf{B}_M has only two distinct eigenvalues, $\lambda = 1$ with multiplicity $(1-\rho)M$ and $\lambda = 2$ with multiplicity ρM . So, for both DMT architectures, the saddle point for the AWGN transmission case can be written as¹

$$f(\tilde{\mathbf{K}}_{\mathbf{x}}^*, \tilde{\mathbf{K}}_{\mathbf{z}}^*) = MK [(1-\rho) \log_2(1+\Lambda) + \rho \log_2(1+\Lambda/2)]. \quad (46)$$

which clearly shows the loss incurred for the system redundancy.

Fig. 3 shows the mutual information (measured in bit per OFDM symbol) that provided by the FMT and the DMT architectures at the Nash equilibrium over an AWGN channel.

¹The differences between (44) and (46) are due to the fact that the sampling frequency F_s is smaller than the system bandwidth, strictly speaking. Hence, in this case, the discrete-time model is an approximation of the continuous-time one.

4.2 FMT systems in channels with a wide coherence band

The analysis of FMT systems is also tractable when both channels from the transmitter and the jammer are frequency selective, provided their coherence band is wider than the subcarrier spacing, that is if we assume

$$\begin{cases} G_T(f) = G_T(f_i) \\ |G_J(f)|^2 = |G_J(f_i)|^2 \end{cases}, \quad f \in \left[f_i - \frac{F}{2}, f_i + \frac{F}{2} \right] \quad (47)$$

Under the above assumptions, the energy matrices in the NS system are diagonal that is by letting $\mathbf{E}_\gamma = \mathbf{E}_\varphi = \mathbf{I}$, $\mathbf{E}_{\varphi'} = \mathbf{G}_J \mathbf{G}_J^*$ and $\mathbf{E}_{\gamma'\varphi} = \mathbf{G}_T$, with $\mathbf{G}_T = \mathbf{I}_K \otimes \text{diag}\{G_T(f_i)\}$ and $\mathbf{G}_J = \mathbf{I}_K \otimes \text{diag}\{G_J(f_i)\}$. Then, it is straightforward to write

$$\mathbf{P} = (\mathbf{G}_T \mathbf{G}_T^*)^{-1/2}, \quad \mathbf{Q} = (\mathbf{G}_J \mathbf{G}_J^*)^{-1/2} \quad (48)$$

$$\tilde{\mathbf{K}}_{\mathbf{w}} = 2N_0 (\mathbf{G}_J \mathbf{G}_J^*)^{-1}, \quad \mathbf{H} = (\mathbf{G}_T \mathbf{G}_T^*)^{1/2} (\mathbf{G}_J \mathbf{G}_J^*)^{-1/2} \quad (49)$$

Then, the system is equivalent to KM parallel channels and the saddle point solution writes

$$f(\mathbf{K}_{\mathbf{x}}^*, \mathbf{K}_{\mathbf{z}}^*) = f(\tilde{\mathbf{K}}_{\mathbf{x}}^*, \tilde{\mathbf{K}}_{\mathbf{z}}^*) = K \sum_{i=1}^M \log \left(1 + \Lambda \frac{|G_T(f_i)|^2}{|G_J(f_i)|^2} \right) \quad (50)$$

with

$$\Lambda = \frac{E_T}{E_J + 2N_0 K \sum_{i=1}^M 1/|G_J(f_i)|^2}. \quad (51)$$

Now, we show that the result in (50) holds also for CS modulation. In this case, as noticed in Section 4.1, the transmit pulses corresponding to different OFDM symbols are not perfectly orthogonal, hence ISI does arise and the energy matrices of the transmitter and receiver filters are not diagonal, but they are given by $\mathbf{E}_\gamma = \mathbf{E}_\varphi = \mathbf{A}$. Nevertheless, if the coherence bandwidth assumptions (47) hold, it is possible to write $\mathbf{E}_{\gamma'\varphi} = \mathbf{G}_T \mathbf{A} = \mathbf{A} \mathbf{G}_T$. Moreover, $\mathbf{E}_{\varphi'} = \mathbf{G}_J \mathbf{G}_J^* \mathbf{A} = \mathbf{A} \mathbf{G}_J \mathbf{G}_J^*$ and the equivalent MIMO channel appearing in the payoff function (26) is

$$\mathbf{H} = \sqrt{\mathbf{E}_{\varphi'}^{-1} (\mathbf{E}_{\gamma'\varphi}^{-1} \mathbf{E}_\gamma \mathbf{E}_{\gamma'\varphi}^{-1})^{-1}} \quad (52)$$

$$= \sqrt{\mathbf{E}_{\varphi'}^{-1} \mathbf{E}_{\gamma'\varphi}^* \mathbf{E}_{\gamma'}^{-1} \mathbf{E}_{\gamma'\varphi}} \quad (53)$$

$$= \sqrt{(\mathbf{G}_J \mathbf{G}_J^*)^{-1} \mathbf{A}^{-1} \mathbf{A}^* \mathbf{G}_T^* \mathbf{A}^{-1} \mathbf{A} \mathbf{G}_T} \quad (54)$$

$$= \sqrt{(\mathbf{G}_J \mathbf{G}_J^*)^{-1} \mathbf{G}_T^* \mathbf{G}_T} \quad (55)$$

as for the NS case. Also the energy constraints (27) and (28) remain unchanged, since

$$\text{tr}(\tilde{\mathbf{K}}_{\mathbf{w}}) = 2N_0 \text{tr}(\mathbf{Q} \mathbf{E}_\varphi \mathbf{Q}) = 2N_0 \text{tr}(\mathbf{Q} \mathbf{Q} \mathbf{E}_\varphi) \quad (56)$$

$$= 2N_0 \text{tr}(\mathbf{E}_{\varphi'}^{-1} \mathbf{E}_\varphi) = 2N_0 \text{tr}((\mathbf{G}_J \mathbf{G}_J^*)^{-1} \mathbf{A}^{-1} \mathbf{A}) \quad (57)$$

$$= 2N_0 K \sum_{i=1}^M \frac{1}{|G_J(f_i)|^2}, \quad (58)$$

and thus, the payoff at the saddle point is the same for both the FMT architectures.

5. THRESHOLDS FOR THE HIGH JNR REGIME

In this section we seek how to determine, for given channels, the minimum value of ρ_J at which the high JNR regime saddle point is feasible. We deal with FMT and DMT systems separately.

5.1 FMT systems

As stated in Section 4.2, under the coherence bandwidth assumptions, the NS system is equivalent to KM parallel channels. In this case, with reference to the saddle point solutions (31), we have that $\mathbf{U}_{\mathbf{H}} = \mathbf{V}_{\mathbf{H}} = \mathbf{I}$, and the optimal covariance matrices are diagonal

$$(\tilde{\mathbf{K}}_{\mathbf{x}}^*, \tilde{\mathbf{K}}_{\mathbf{z}}^*) = (\boldsymbol{\Sigma}_{\mathbf{x}}, \boldsymbol{\Sigma}_{\mathbf{z}}). \quad (59)$$

The optimal power allocation strategies, that is, the entries of $\boldsymbol{\Sigma}_{\mathbf{x}} = \text{diag}\{\sigma_{x,i}\}$ and $\boldsymbol{\Sigma}_{\mathbf{z}} = \text{diag}\{\sigma_{z,i}\}$, can be derived from the results in [16] about the optimal power allocation for the jamming game over parallel Gaussian channels. We denote with $h_i = \lambda_i(\mathbf{H}\mathbf{H}^*)$ the diagonal elements (eigenvalues) of the matrix $\mathbf{H}\mathbf{H}^*$ and we use the symbol $\tilde{w}_\ell = \lambda_\ell(\tilde{\mathbf{K}}_{\mathbf{w}})/(2N_0)$ to denote the diagonal entries of $\tilde{\mathbf{K}}_{\mathbf{w}}$ normalized over the thermal noise PSD $2N_0$. Then, the application of [16, Lemma 1][15] yields

$$\sigma_{x,i} = \frac{h_i}{\lambda(h_i + \lambda/\nu)} \quad (60)$$

$$\sigma_{z,i} = \frac{h_i}{\nu(h_i + \lambda/\nu)}, \quad (61)$$

in which the constants $\lambda, \nu \geq 0$ are chosen in order to satisfy the energy constraints

$$\sum_{i=1}^{KM} \sigma_{x,i} \leq E_T \quad (62)$$

$$\sum_{i=1}^{KM} \sigma_{z,i} \leq E_J + 2N_0 \sum_{\ell=1}^{KM} \tilde{w}_\ell. \quad (63)$$

Then, we obtain

$$\frac{\nu}{\lambda} = \Lambda = \frac{E_T}{E_J + 2N_0 \sum_{\ell} \tilde{w}_\ell} \quad (64)$$

and

$$\nu = \frac{\sum_i \frac{h_i}{h_i + 1/\Lambda}}{E_J + 2N_0 \sum_{\ell} \tilde{w}_\ell}. \quad (65)$$

Hence, (61) gives a feasible solution when all the elements of the corresponding diagonal matrix $\mathbf{K}_{\mathbf{s}}^*$ are non negative, that is when

$$\frac{1}{\tilde{w}_i} \sigma_{z,i} - 2N_0 \geq 0, \quad \forall i. \quad (66)$$

It is straightforward to show that the conditions in (66) are equivalent to impose $c_i(\rho_J, \rho_T) \geq 0$, $\forall i$, where

$$c_i(\rho_J, \rho_T) = \rho_J + 2 \sum_{\ell} \tilde{w}_\ell - 2\tilde{w}_i \sum_{k=1}^{MK} \frac{\rho_T + \frac{\rho_J + 2 \sum_{\ell} \tilde{w}_\ell}{h_i} \tilde{w}_\ell}{\rho_T + \frac{\rho_J + 2 \sum_{\ell} \tilde{w}_\ell}{h_k} \tilde{w}_\ell}. \quad (67)$$

Observe that since

$$\lim_{\rho_J \rightarrow \infty} c_i(\rho_J, \rho_T) = +\infty, \quad \forall \rho_T \quad (68)$$

there exists, for each i and any SNR value ρ_T a threshold on the JNR for $c_i(\rho_J, \rho_T)$ to be non negative,

$$\bar{\vartheta}_i(\rho_T) = \inf \{ \vartheta \geq 0 : c_i(\rho_J, \rho_T) \geq 0, \forall \rho_J \geq \vartheta \} \quad (69)$$

Therefore, we can retrieve a condition on the available JNR that is sufficient to guarantee the feasibility of the solution (61), that is

$$\rho_T \geq \vartheta_{\max}(\rho_T) = \max_i \bar{\vartheta}_i(\rho_T) \quad (70)$$

It is interesting to explore the behavior of the thresholds defined above in both the low and high SNR regimes. In the low SNR regime, that is for $\rho_T = 0$ we have

$$c_i(\rho_J, 0) = \rho_J + 2 \sum_{\ell} \tilde{w}_{\ell} - 2\tilde{w}_i \sum_{k=1}^{MK} \frac{h_k}{h_i} \quad (71)$$

and

$$\bar{\vartheta}_i(0) = \max \left\{ 0, 2 \frac{\tilde{w}_i}{h_i} \sum_{k=1}^{MK} h_k - 2 \sum_{\ell} \tilde{w}_{\ell} \right\}. \quad (72)$$

Hence the threshold

$$\vartheta_{\max}(0) = 2 \max_i \left\{ \frac{\tilde{w}_i}{h_i} \sum_{k=1}^{MK} h_k - 2 \sum_{\ell} \tilde{w}_{\ell} \right\} \quad (73)$$

depends on the maximal attenuation in the main channel, $\max \tilde{w}_i/h_i = \max 1/|G_T(f_i)|^2$.

In the high SNR regime, we have

$$\lim_{\rho_T \rightarrow \infty} c_i(\rho_J, \rho_T) = \rho_J + 2 \sum_{\ell} \tilde{w}_{\ell} - 2\tilde{w}_i MK \quad (74)$$

and

$$\lim_{\rho_T \rightarrow \infty} \bar{\vartheta}_i(\rho_T) = \max \left\{ 0, 2\tilde{w}_i MK - 2 \sum_{\ell} \tilde{w}_{\ell} \right\}. \quad (75)$$

Hence, in the high SNR, the threshold

$$\lim_{\rho_T \rightarrow \infty} \vartheta_{\max}(\rho_T) = 2MK \max_i \{ \tilde{w}_i \} - 2 \sum_{\ell} \tilde{w}_{\ell} \quad (76)$$

is determined by the maximal attenuation in the jammer channel, $\max \tilde{w}_i = \max 1/|G_J(f_i)|^2$. In Figure 4 we show the threshold on the JNR as a function of the SNR ρ_T for a single channel realization. The values of the threshold in the intermediate SNR regime are numerically evaluated starting from (67).

Now, we show that this threshold on the JNR is the same for the CS system. In Section 4.2, we have shown that both FMT architectures share the same expression for the matrices \mathbf{H} , $\tilde{\mathbf{K}}_{\mathbf{w}}$ and the trace constraints (27), (28). Hence they share the same minimax solution covariance matrices ($\tilde{\mathbf{K}}_{\mathbf{x}}^*$, $\tilde{\mathbf{K}}_{\mathbf{z}}^*$), that are therefore diagonal also for the CS case and whose elements are obtained from equations (60) and (61). Then, the corresponding optimal covariance matrix for the jamming signal is $\mathbf{K}_{\mathbf{s}}^* = \mathbf{Q}^{-1} \tilde{\mathbf{K}}_{\mathbf{s}}^* \mathbf{Q}^{-1} = \mathbf{Q}^{-1} (\tilde{\mathbf{K}}_{\mathbf{z}}^* - \tilde{\mathbf{K}}_{\mathbf{w}}) \mathbf{Q}^{-1}$. Then, it is easy to observe that the optimal jammer covariance matrix for the CS system is positive semidefinite if and only if the corresponding matrix of the NS case is positive semidefinite as well, as the matrix \mathbf{Q} is positive semidefinite.

5.2 DMT systems

For the case of transmission with a DMT system, the conditions that guarantee the feasibility of the high JNR solution are more complicated to express and must be computed numerically. We recall that the equivalent jammer covariance matrix $\mathbf{K}_{\mathbf{z}}^*$ is optimally beamformed along the left singular vectors of the channels \mathbf{H} and the corresponding transmitter covariance matrix $\tilde{\mathbf{K}}_{\mathbf{x}}^*$ along the right singular vectors of \mathbf{H} . This way, the system is reduced to the parallel of KM

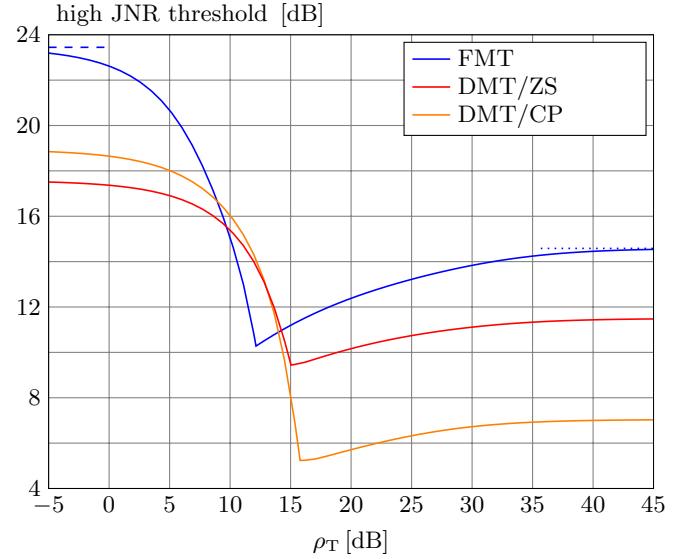

Figure 4: High JNR thresholds on ρ_J for the different OFDM architectures. The threshold limits for FMT given in (73) and (76) are shown in dashed and dotted blue lines, respectively.

orthogonal channels, for which the optimal power allocation strategies are given again by (60) and (61) with h_i being the i -th element of the main diagonal of $\Sigma_{\mathbf{H}}$. Then, the condition on the positive semidefinite nature of $\mathbf{K}_{\mathbf{s}}^*$ is numerically checked by expressing this matrix as

$$\mathbf{K}_{\mathbf{s}}^* = \mathbf{Q}^{-1} \mathbf{U}_{\mathbf{H}} \Sigma_{\mathbf{z}} \mathbf{U}_{\mathbf{H}}^* \mathbf{Q}^{-1} - 2N_0 \mathbf{E}_{\varphi}. \quad (77)$$

The JNR threshold is then evaluated numerically with a binary search method, and is illustrated in Figure 4 as a function of the SNR.

6. GENERAL SOLUTION

In this case, the matrix $\tilde{\mathbf{K}}_{\mathbf{w}}$ is fixed and determined by the system, and the jammer can operate only on $\tilde{\mathbf{K}}_{\mathbf{s}}$ in order to disrupt the communication performance. When the power available to the jammer is limited, and the saddle point solution in Section 4 is not feasible, it is still possible to find the optimal jamming strategy for the case when FMT transmission is implemented. For the DMT system we will propose an efficient jamming scheme that is shown to converge to the optimal solution when the JNR enters the feasibility region described in the previous section.

6.1 FMT systems in channels with a wide coherence band

We start by considering the NS case. The parallel channel structure obtained under the coherence bandwidth assumptions can be leveraged to apply to this case the result on the optimal jamming and transmitter power allocation in [16, 15]. Since we want to handle the jamming signal separately and independently from the AWGN at the receiver,

we express the payoff function as

$$f(\tilde{\mathbf{K}}_{\mathbf{x}}, \tilde{\mathbf{K}}_{\mathbf{s}}) = \sum_{i=1}^{MK} \log_2 \left(1 + \frac{h_i \sigma_{x,i}}{\sigma_{s,i} + 2N_0 \tilde{w}_i} \right) \quad (78)$$

subject to the power constraints

$$\sum_i \sigma_{x,i} \leq E_T \quad (79)$$

$$\sum_i \sigma_{s,i} \leq E_J, \quad (80)$$

in which $\sigma_{x,i}, \sigma_{s,i}$ are the diagonal elements of the (diagonal) matrices $\tilde{\mathbf{K}}_{\mathbf{x}}, \tilde{\mathbf{K}}_{\mathbf{s}}$, respectively. The optimal power allocations for the transmitter and the jammer are obtained from [16, Lemma 1], by substituting the noise PSD value with the corresponding element in $\tilde{\mathbf{K}}_{\mathbf{w}}$, that is with the values $2N_0 \tilde{w}_i$. Namely,

$$\sigma_{x,i} = \begin{cases} \left(\frac{1}{\lambda} - \frac{2N_0 \tilde{w}_i}{h_i} \right)^+ & , h_i \leq \frac{2N_0 \tilde{w}_i \lambda}{1 - 2N_0 \tilde{w}_i \nu} \\ \frac{h_i}{\lambda(h_i + \lambda/\nu)} & , h_i > \frac{2N_0 \tilde{w}_i \lambda}{1 - 2N_0 \tilde{w}_i \nu} \end{cases} \quad (81)$$

$$\sigma_{s,i} = \begin{cases} 0 & , h_i \leq \frac{2N_0 \tilde{w}_i \lambda}{1 - 2N_0 \tilde{w}_i \nu} \\ \frac{h_i}{\nu(h_i + \lambda/\nu)} - 2N_0 \tilde{w}_i & , h_i > \frac{2N_0 \tilde{w}_i \lambda}{1 - 2N_0 \tilde{w}_i \nu} \end{cases} \quad (82)$$

with $\lambda, \nu \geq 0$ such that the energy constraints (79) and (80) are verified.

For what we have seen in the previous sections, the CS system has the same saddle point solution ($\tilde{\mathbf{K}}_{\mathbf{x}}^*, \tilde{\mathbf{K}}_{\mathbf{s}}^*$) and the same payoff function. Moreover, the optimal covariance matrices for CS are obtained as usual by multiplying the diagonal matrices ($\tilde{\mathbf{K}}_{\mathbf{x}}^*, \tilde{\mathbf{K}}_{\mathbf{s}}^*$) by the matrix \mathbf{A} .

6.2 DMT systems

In this case the system can not be modeled as parallel Gaussian channels, and we must rely on the general MIMO expression of the minimax problem (22). As explained in Section 4, the optimal strategy for the jammer would yield

$$\tilde{\mathbf{K}}_{\mathbf{w}} + \tilde{\mathbf{K}}_{\mathbf{s}} = \mathbf{U}_{\mathbf{H}} \Sigma_{\mathbf{z}} \mathbf{U}_{\mathbf{H}}^* \quad (83)$$

However, in the general case with finite JNR, the energy available at the jammer could be not sufficient to provide a total interference signal (jamming signal plus thermal noise) beamed along the left singular vectors of the channel \mathbf{H} . Nevertheless, we aim to provide a jamming strategy that exploits the optimal directions as soon as the JNR enters the feasibility region of Section 5

$$\tilde{\mathbf{K}}_{\mathbf{w}} = \hat{\mathbf{K}}_{\mathbf{w}} + \Delta_{\mathbf{w}} = \mathbf{U}_{\mathbf{H}} \hat{\Sigma}_{\mathbf{w}} \mathbf{U}_{\mathbf{H}}^* + \Delta_{\mathbf{w}}, \quad (84)$$

in which $\hat{\Sigma}_{\mathbf{w}} = \text{diag}\{\hat{\sigma}_{w,i}\}$, with $\hat{\sigma}_{w,i} \geq 0$, for $i = 1, \dots, KM$ and

$$\sum_{i=1}^{KM} \hat{\sigma}_{w,i} = \text{tr}(\tilde{\mathbf{K}}_{\mathbf{w}}). \quad (85)$$

Therefore, $\text{tr}(\Delta_{\mathbf{w}}) = 0$ and the Hermitian matrix $\Delta_{\mathbf{w}}$ represents the deviation of the noise covariance matrix from the optimal noise directions. Analogously, we constrain the jammer covariance matrix to be written as

$$\tilde{\mathbf{K}}_{\mathbf{s}} = \mathbf{U}_{\mathbf{H}} \hat{\Sigma}_{\mathbf{s}} \mathbf{U}_{\mathbf{H}}^* + \Delta_{\mathbf{s}}, \quad (86)$$

in which $\hat{\Sigma}_{\mathbf{s}} = \text{diag}\{\hat{\sigma}_{s,i}\}$, with $\hat{\sigma}_{s,i} \geq 0$, for $i = 1, \dots, KM$. Moreover, we choose $\Delta_{\mathbf{s}}$ as

$$\Delta_{\mathbf{s}} = -\alpha \Delta_{\mathbf{w}}, \quad (87)$$

with $\alpha \in [0, 1]$. Therefore, $\text{tr}(\Delta_{\mathbf{s}}) = 0$ and we impose

$$\sum_{i=1}^{KM} \hat{\sigma}_{s,i} \leq E_J. \quad (88)$$

The parameter α is chosen as the maximum value in $[0, 1]$ such that the corresponding matrix $\tilde{\mathbf{K}}_{\mathbf{s}}$ is still positive semidefinite. The idea underlying this choice is to obtain the total interference covariance matrix

$$\tilde{\mathbf{K}}_{\mathbf{w}} + \tilde{\mathbf{K}}_{\mathbf{s}} = \mathbf{U}_{\mathbf{H}} (\hat{\Sigma}_{\mathbf{w}} + \hat{\Sigma}_{\mathbf{s}}) \mathbf{U}_{\mathbf{H}}^* + (1 - \alpha) \Delta_{\mathbf{w}} \quad (89)$$

in which the effect of the term $(1 - \alpha) \Delta_{\mathbf{w}}$ is reduced to the minimum, in order to distribute the jamming signal energy across the optimal directions determined by the matrix $\mathbf{U}_{\mathbf{H}}$. In order to achieve this task, we define a two step optimization protocol that leads to the definition of the suitable $\tilde{\mathbf{K}}_{\mathbf{s}}$ to be adopted by the attacker.

Decomposition of $\tilde{\mathbf{K}}_{\mathbf{w}}$

The values of the matrix $\hat{\Sigma}_{\mathbf{w}}$, and the corresponding values of $\Delta_{\mathbf{w}}$ in (84), are chosen as the solution of the following optimization problem

$$\begin{aligned} & \underset{\hat{\Sigma}_{\mathbf{w}}}{\text{maximize}} && \alpha_0 = \frac{\min_i \{\hat{\sigma}_{s,i}\}}{\max_{\ell} \{\lambda_{\ell}(\Delta_{\mathbf{w}})\}} \\ & \text{subject to} && \hat{\sigma}_{w,i} \geq 0, \quad i = 1, \dots, KM, \\ & && \hat{\sigma}_{s,i} \geq 0, \quad i = 1, \dots, KM, \\ & && \sum_i \hat{\sigma}_{w,i} = \text{tr}(\tilde{\mathbf{K}}_{\mathbf{w}}) \\ & && \sum_i \hat{\sigma}_{s,i} \leq E_J. \end{aligned} \quad (90)$$

For each value of $\hat{\Sigma}_{\mathbf{w}}$ in (90), the corresponding elements in $\hat{\Sigma}_{\mathbf{s}}$ are computed according to the optimal power allocation² in (82), by substituting the terms $2N_0 \tilde{w}_i$ with $\hat{\sigma}_{w,i}$.

Definition of α

The optimization problem in (90) provides the expressions for $\hat{\Sigma}_{\mathbf{w}}, \hat{\Sigma}_{\mathbf{s}}$ and $\Delta_{\mathbf{w}}$. The last parameter to tune in the definition of the jamming strategy is α in (87). Again, α is defined as the solution of a maximization problem, that is numerically solved, and starts from the initial point

$$\alpha_0 = \frac{\min_i \{\hat{\sigma}_{s,i}\}}{\max_{\ell} \{\lambda_{\ell}(\Delta_{\mathbf{w}})\}}. \quad (91)$$

On leveraging Weyl's Theorem (4.3.1) and the Corollary (6.3.4) in [9], we can state that

$$\lambda_{\min}(\tilde{\mathbf{K}}_{\mathbf{s}}) \geq \min_i \{\hat{\sigma}_{s,i}\} - \alpha \lambda_{\max}(\Delta_{\mathbf{w}}), \quad (92)$$

hence, on choosing $\alpha = \alpha_0$, the corresponding jamming covariance matrix is positive semidefinite and it represents a valid jamming strategy. On top of that, the actual value of α adopted by the jammer is further optimized, starting

²The optimal jamming power allocation must be computed jointly with the optimal transmitter power allocation (81).

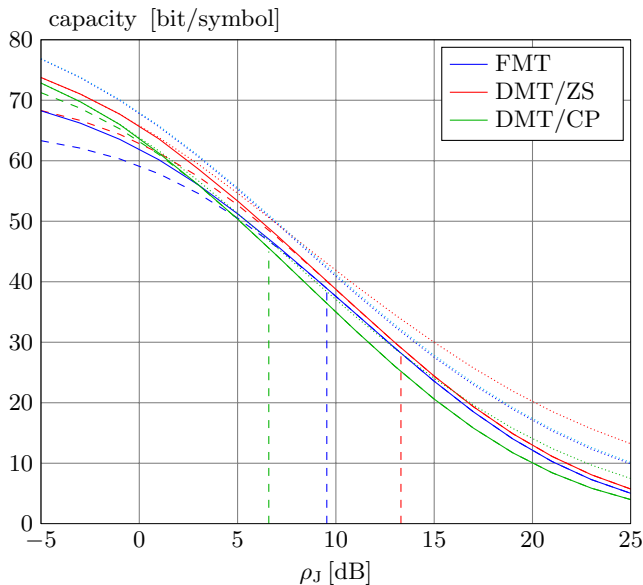

Figure 5: Mutual information at the saddle point vs. JNR, for OFDM transmissions over a single realization of a Rayleigh fading channel for $\rho_T = 20$ dB (solid lines). The dashed lines indicate the solution obtained by relaxing the constraint (28) and the dashed vertical lines indicate the threshold on JNR beyond which the two solutions coincide. The dotted lines show the optimal solution obtained by the transmitter when the jammer chooses \mathbf{v} with iid components, so that $\mathbf{K}_v = \sigma_v^2 \mathbf{I}$.

from α_0 , as the highest value in $[0, 1]$ the provides a positive semidefinite $\tilde{\mathbf{K}}_s$. This last optimization is performed numerically via an iterative binary search algorithm.

Then, once the adopted $\tilde{\mathbf{K}}_s$ is chosen, the corresponding best $\tilde{\mathbf{K}}_x$ for the transmitter is chosen according to the waterfilling principle, as the solution yielding the highest mutual information given the channel, the noise and the jammer expressions.

Results for a single realization of a dispersive channel are plotted in Figure 5, where we can observe that the high JNR solutions provide a sensibly lower result as ρ_J moves further back from the thresholds. It is also possible to appreciate the gain for the jammer to use the optimal strategy rather than a simple uniform power allocation across waveforms that are matched to the receiver ones.

7. CONCLUSIONS

We have considered the mutual information jamming game in the particular case of an OFDM system. By rewriting it as a MIMO system we have been able to apply some results from the literature on the jamming game in a MIMO setting and to derive the optimal strategies and the value of the payoff function at the saddle point that solves the minimax problem. In particular, we have given closed form expressions for the case in which the channels are AWGN, and a waterfill-like expression for dispersive channels with

the FMT system, while for the DMT system in a dispersive channel we give a numerical solution. We have also identified the thresholds on the JNR that allow simplification of the problem, as if the jammer could control the total disturbance (jamming + noise).

We remark that in our analysis we assume that all terminals have perfect knowledge of the channels, and that the jamming is uncorrelated with the information-bearing signal.

As a future work, we wish to extend our analysis to the case where each player (transmitter or jammer) only has knowledge only on the state of his own channel. Subsequently, we also aim to the case where the jammer can observe the transmitted signal through the channel that links the transmitter to the jammer himself, and choose a correlated jamming.

8. REFERENCES

- [1] G. Amariuca and W. Shuangqing. Jamming Games in Fast-Fading Wireless Channels. *IEEE GLOBECOM*, 1–5, 2008.
- [2] G. T. Amariuca and S. Wei. Jamming in Fixed-Rate Wireless Systems with Power Constraints - Part I: Fast Fading Channels. *ArXiv*, abs/0808.3431:1–34, 2008.
- [3] T. Başar. The Gaussian Test Channel with an Intelligent Jammer. *IEEE Trans. Inf. Theory*, 29(1):152–157, 1983.
- [4] T. Başar and Y.-W. Wu. A Complete Characterization of Minimax and Maximin Encoder-Decoder Policies for Communication Channels with Incomplete Statistical Description. *IEEE Trans. Inf. Theory*, 31(4):482–489, 1985.
- [5] A. Bayesteh, M. Ansari, and A. K. Khandani. Effect of jamming on the capacity of MIMO channels. In *Allerton Conference*, 401–410, 2004.
- [6] A. Best and B. Natarajan. The effect of jamming on the performance of carrier interferometry/OFDM. In *IEEE WiMob*, vol. 1, 66–70, 2005.
- [7] F. J. Block. Comparison of Jamming Robustness of Airborne Networking Waveforms. In *IEEE MILCOM*, 1–7, 2005.
- [8] G. Cherubini, E. Eleftheriou, and S. Olcer. Filtered multitone modulation for very high-speed digital subscriber lines. *IEEE J. Sel. Ar. Comm.*, 20(5):1016–1028, June 2002.
- [9] R. A. Horn and C. R. Johnson. *Matrix analysis*. Cambridge University Press, Cambridge, 1990.
- [10] E. A. Jorswieck. *Unified approach for optimisation of single-user and multi-user multiple-input multiple-output wireless systems*. Ph.d. Thesis, Technische Universität Berlin, 2004.
- [11] E. A. Jorswieck, H. Boche, and M. Weckerle. Optimal Transmitter and Jamming Strategies in Gaussian MIMO Channels. In *IEEE VTC-Spring*, vol. 2, 978–982, 2005.
- [12] A. Kashyap, T. Başar, and R. Srikant. Correlated Jamming on MIMO Gaussian Fading Channels. *IEEE Trans. Inf. Th.*, 50(9):2119–2123, 2004.
- [13] B. Muquet, Z. Wang, G. B. Giannakis, M. de Courville, and P. Duhamel. Cyclic prefixing or zero padding for wireless multicarrier transmissions?

IEEE Trans. Comm., 50(12):2136–2148, 2002.

[14] S. Ray, P. Moulin, and M. Medard. On Jamming in the Wideband Regime. In *IEEE ISIT*, 2574–2577, 2006.

[15] S. Shafiee and S. Ulukus. Capacity of Multiple Access Channels with Correlated Jamming. In *IEEE*

MILCOM, vol. 1, 218–224, 2005.

[16] S. Wei and R. Kannan. Jamming and counter-measure strategies in parallel Gaussian fading channels with channel state information. In *IEEE MILCOM*, 1-7, 2008.